

M2i.46XX - 8-Channel, up to 3 MS/s, **FAST** 16 bit, PCI-based Transientrecorders

Features:

- PCI-X interface (100% compatible to PCI)
- 16bit A/D converter board
- Up to 3 MS/s on one, two, four or eight channels
- Separate ADC and Amplifier per channel
- Simultaneous sampling on all channels
- 8 input ranges: ± 50 mV up to ± 10 V
- 64 MB on-board memory expandable to 4 GB
- Sustained streaming mode to 200 MB/s
- Window, pulse-width, re-arm, OR/AND trigger
- Programmable input offset up-to +/- 200%
- Synchronization option for up-to 16 boards
- ABA mode option: combination of data logging and digitizing on trigger
- Software support for Windows and LINUX

Description:

The M2i.46xx series allows recording of one, two, four or eight channels with sampling rates of 200 kS/s up to 3 MS/s. These cards offer outstanding A/D features both in resolution and speed for PCI/PCI-X. They are available in several versions and different speed grades making it possible for the user to find an individual solution. The installed memory of up to 2 GSample can be used for fast data recording or sustained data streaming. The enhanced FIFO engine is capable of streaming even 8 channels with 3 MS/s sustained to memory or hard disk.

- Completely new developed base card
- 4 GByte memory with one slot width
- Optimized low jitter clock section
- Multi, Gate with programmable pre, posttrigger and timestamp
- Zero phase delay synchronization
- AND/OR conjunction of trigger/gate



M2i.46xx 23062006

Model	1 channel	2 chan.	4 chan.	8 chan.
M2i.4620	200 kS/s	200 kS/s		
M2i.4621	200 kS/s	200 kS/s	200 kS/s	
M2i.4622	200 kS/s	200 kS/s	200 kS/s	200 kS/s
M2i.4630	500 kS/s	500 kS/s		
M2i.4631	500 kS/s	500 kS/s	500 kS/s	
M2i.4632	500 kS/s	500 kS/s	500 kS/s	500kS/s
M2i.4640	1 MS/s	1 MS/s		
M2i.4641	1 MS/s	1 MS/s	1 MS/s	
M2i.4642	1 MS/s	1 MS/s	1 MS/s	1 MS/s
M2i.4650	3 MS/s	3 MS/s		
M2i.4651	3 MS/s	3 MS/s	3 MS/s	
M2i.4652	3 MS/s	3 MS/s	3 MS/s	3 MS/s

Applications:

- Automation
- Production Test
- Quality control
- ATE
- Military
- Automotive

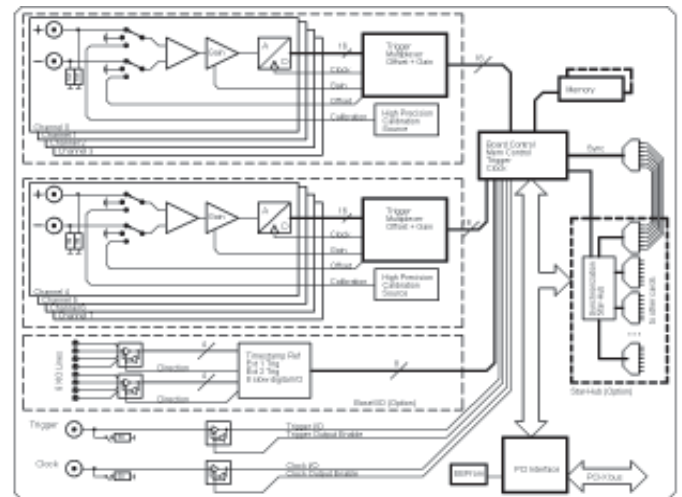

Hardware block diagram

Product range overview

All four cards of the M2i.46xx series may use the whole installed on-board memory completely for the currently activated number of channels. See details above

Specifications:

RESOLUTION: 16bit

DIFF. NONLINEARITY: ± 2 LSB 465x, all others ± 1 LSB

INTEGRAL NONLINEARITY: as above

OFFSET ERROR: ≤ 01 LSB (after calibration)

GAIN ERROR: $< 1\%$ (after calibration)

PROGRAMMABLE INPUT OFFSET: ± 5 V for single ended ranges ± 10 V

CROSSTALK @ 1 MHz, 50 Ohm: < -80 db between any adjacent channel

CROSSTALK @ 100 kHz signal: ≤ -110 db between any adjacent channel, 50 Ohm terminated

ANALOG INPUT impedance: 1 MOhm against GND

OVER VOLTAGE PROTECTION: ± 30 V all ranges

CMRR ± 50 mV to ± 500 mV: > 70 dB

CMRR ± 1 V to ± 10 V: > 46 dB

CONNECTOR (analog and trigger/clock): 3mm SMB m

MULTI, GATE, re-arming time: < 4 Samples

MAX PRETRIGGER at MULTI, GATE; FIFO: 8176 samples as sum of all active channels

CHANNEL TRIGGER RES.: 14 Bit

TRIGGER OUTPUT delay: one pos. edge after int. trigger

EXT.TRIGGER type: TTL compatible

EXT.TRIGGER input: low ≤ 0.8 V, high ≥ 2 V, ≥ 2 clock periods

EXT.TRIGGER max voltage: -0.5 V to $+5.5$ V

EXT.TRIGGER output levels: TTL comp.

EXT.TRIGGER output: capable of driving a 50 Ohm load

INTERNAL CLOCK accuracy: 20 ppm

INT. CLOCK RANGE: 1 kS/s to max.- see table

INT. CLOCK max. jitter (PPL mode):

INT. CLOCK max. jitter (Quartz mode):

INT. CLOCK stepsize: $\leq 1\%$ of range (100M, 10M..)

INT. CLOCK stepsize example: range 1 to 10MS/s: stepsize ≤ 100 k

EXT. CLOCK RANGE: 1 MS/s to max.-see table

EXT. CLOCK DELAY to int. clock:

EXT. CLOCK INPUT: low ≤ 0.8 V, high ≥ 2 V, duty 45-55%

EXT. CLOCK max. voltage: -0.5 V to $+5.5$ V

EXT. CLOCK output: low ≤ 0.4 V, high ≥ 2.4 V (TTL)

EXT. CLOCK output: capable of driving a 50 Ohm load

REF. CLOCK-EXT.CLOCK RANGE: ≥ 4 MHz ≤ 125 MHz

DIMENSION: 312 x 107 mm (full lengths PCI board)

With STAR-HUB 5 / 16: 1 / 2 full size slot

WEIGHT: from 290g to 460g (8channels + Star-hub (w/o packing))

WARMUP TIME: 10 min

OPERATING TEMP RANGE: 0 to 50 °C

STORAGE TEMP RANGE: -10 to 70 °C

HUMIDITY: 10% to 90%

Please note: The M2i.46x-Series Transientrecorders extensively use SMB connectors. Cables with these connectors are not included with the boards. They have to be ordered separately if required.



FAST ComTec supports LINUX

Software programmable parameters M2i.46xx		Software programmable parameters M2i.46xx	
Input range	± 50 mV to ± 10 V in steps of 1, 2, 5	Trigger mode	Channel, External, SW, Auto, Pulse
Input Type	Single ended, true differential		Window, Re-arm, OR/AND, Delay
Input Offset s.end.	progr. To ± 5 V in steps of 1mV, not exc. ± 10 V	Trigger resolution	14 bit resolution
Clock mode	Int. PLL, int. Quartz, ext clock, ext.div. Ext.ref.	Triggeredge	rising edge, falling edge or both edges
	clock, sync	Trigger pulsewidth	0 to /64k-1) samp. in steps of 1 samp.
Clock impedance	50 Ohm / high impedance (> 4 kOhm)	Trigger delay	0 to /64k-1) samp. in steps of 1 samp.
Trigger impedance	50 Ohm / high impedance (> 4 kOhm)	Post trigger	4 up to (8G-4) samples in steps of 4
Memory depth	8 up to (installed memory/2/active channels	Multiple Rec. Seg.	8 up to (installed memory/2/active
	in steps of 4		channels in steps of 4
Channel selection	Any 1, 2, 4 or 8 channels	Multi/Gated pretrigger	0 up to (16k sampl./active chan.-16)
ABA Clock Driver	1 up to (64-1) in steps of 1	Sync. Clock driver	2 up to (8k-2) in steps of 2

Power Consumption (max speed)	3.3 V	5 V	-12 V	+12 V	Total
M2i.46x0 (32 MS memory)	1.9 A	0.6 A	n.u.	n.u.	9.3 W
M2i.46x1 (32 MS memory)	2.2 A	1.2 A	n.u.	n.u.	13.3 W
M2i.46x2 (32 MS memory)	2.8 A	2.4 A	n.u.	n.u.	21.2 W
M2i.4652 (32 MS memory)	3.9 A	2.4 A	n.u.	n.u.	24.9 W

Software Support

Windows drivers

The cards are delivered with drivers for Windows 2000, Windows XP, Windows XP64 and Windows Vista (Beta). Programming examples for Visual C/C++, Borland C++ Builder, Gnu C, LabWindows/CVI, Borland Delphi and Visual Basic are included.

Linux Drivers

All cards are delivered with full Linux support. Pre compiled kernel modules are included for the most common distributions like RedHat, Suse or Debian. The linux support is enhanced by SMP support, versatile programming examples as well as the possibility to get the driver sources for own compilation.

SBench

A full licence of SBench the easy-to-use graphical operating software for the Spectrum cards is included in the delivery. The version 6 is running under Windows as well as under Linux (KDE and GNOME)

Third-party products

A lot of third-party products are supported as an option. Choose between LabVIEW, MATLAB, DASyLab and Agilent VEE. All drivers come with examples and detailed documentation.

MI Software compatibility layer

To allow an easy change from MI cards to the new M2i cards for existing software a special software compatibility layer is delivered with the cards. This DLL converts MI calls to M2i calls and simulates a MI card in the software.

Hardware features and options

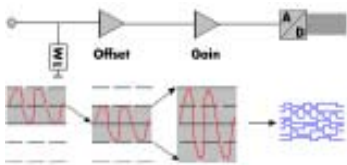

The analog inputs can be adapted to real world signals using a wide variety of settings that are individual for each channel. By using software commands the input termination can be changed between 50 Ohm and 1

MOhm, one can select a matching input range and the signal offset can be compensated for.

Ring buffer mode

Ring buffer mode

The ring buffer mode is the standard mode of all oscilloscope boards. Data is written in a ring memory of the board until a trigger event is detected. After the event the posttrigger values are recorded. Because of this continuously recording into a ring buffer there are also samples prior to the trigger event visible: $\text{Pretrigger} = \text{Memsize} - \text{Posttrigger}$.

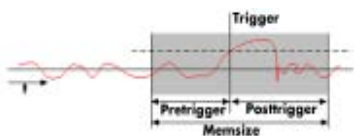

FIFO mode

The FIFO mode is designed for continuous data transfer between measurement board and PC memory (up to 225 MB/s on a PCI-X slot and up to 115 MB/s on a PCI slot) or hard disk. The control of the data stream is done automatically by the driver on interrupt request. The

complete installed on-board memory is used for buffer data, making the continuous streaming extremely reliable.

Channel trigger

The data acquisition boards offer a wide variety of trigger modes. Besides the standard signal checking for level and edge as known from oscilloscopes it's also possible to define a window trigger. All trigger modes can be combined with the pulsewidth trigger. This makes it possible to trigger on signal errors like too long or too short pulses. In addition to this a re-arming mode (for accurate trigger recognition on noisy signals) the AND/OR conjunction of different trigger events is possible. As a unique feature it is possible to use deactivated channels as trigger sources.

External trigger I/O

All boards can be triggered using an external TTL signal. It's possible to use positive or negative edge also in combination with a programmable pulse width. An internally recognised trigger event can - when activated by software - be routed to the trigger connector to start external instruments.

Pulse width

Defines the minimum or maximum width that a trigger pulse must have to generate a trigger event. Pulse width can be combined with channel trigger, pattern trigger and external trigger.

Multiple Recording

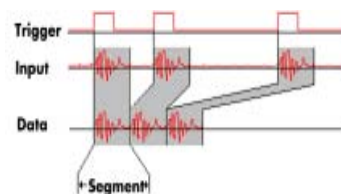

The Multiple Recording option allows the recording of several trigger events with an extremely short re-arming time. The hardware doesn't need to be restarted in between.

The on-board memory is divided in several segments of the same size. Each of

them is filled with data if a trigger event occurs. Pre- and posttrigger of the segments can be programmed. The number of acquired segments is only limited by the used memory and is unlimited when using FIFO mode.

Gated Sampling

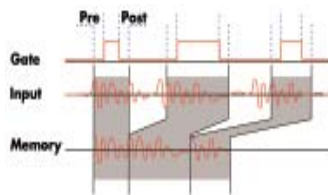

The Gated Sampling option allows data recording controlled by an external gate signal. Data is only recorded if the gate signal has a programmed level. In addition a pre-area before start of the gate signal as well as a post area after end of the gate signal can be acquired. The number of gate segments is

only limited by the used memory and is unlimited when using FIFO mode.

Timestamp

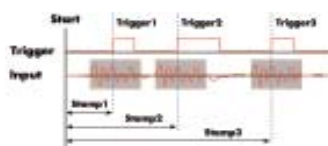

The timestamp option writes the time positions of the trigger events in an extra memory. The timestamps are relative to the start of recording, a defined zero time, externally synchronised to a radio clock, or a GPS receiver.

With this option acquisitions of systems on different locations can be set in a precise time relation.

ABA mode

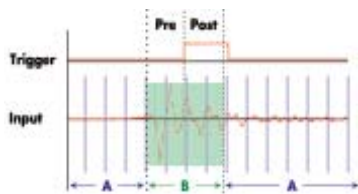

timestamps in an extra memory.

External clock I/O

Using a dedicated connector a sampling clock can be fed in from an external system. It's also possible to output the internally used sampling clock to synchronise external equipment to this clock.

Reference clock

The option to use a precise external reference clock (normally 10 MHz) is necessary to synchronise the board for high-quality mea-

The optional ABA mode combines slow continuous data recording with fast acquisition on trigger events. The ABA mode works like a slow data logger combined with a fast digitizer. The exact position of the trigger events is stored as

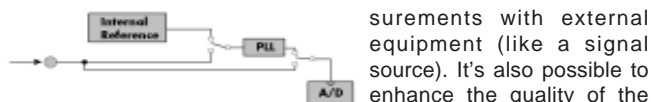

The driver automatically generates the requested sampling clock from the fed in reference clock.

Star-Hub

The star-hub is an additional module allowing the phase stable synchronisation of up to 16 boards. Independent of the number of boards there is no phase delay between all channels. The star-hub distributes trigger and clock information between all boards. As a result all connected boards are running with the same clock and the same trigger. All trigger sources can be combined with OR/AND allowing all channels of all cards to be trigger source at the same time. The star-hub is available as 5 card and 16 card version. The 5 card version doesn't need an extra slot.



	M2i.4620 M2i.4621 M2i.4622	M2i.4630 M2i.4631 M2i.4632	M2i.4640 M2i.4641 M2i.4642	M2i.4650 M2i.4651 M2i.4652
Dynamic Parameters				
Max internal or external clock	200 kS/s	500 kS/s	1 MS/s	3 MS/s
-3 dB bandwidth	> 100 kHz	> 250 kHz	> 500 kHz	> 1,5 MHz
Zero noise level at 50 Ohm	TBD	TBD	TBD	TBD
Test Rate	200 kS/s	500 kS/s	1 MS/s	3 MS/s
Test signal frequency	1 / 10 kHz	1 / 10 kHz	10 / 100 kHz	10 / 100 kHz
SNR typ. (dB)	TBD	TBD	TBD	TBD
THD typ. (dB)	TBD	TBD	TBD	TBD
SFDR typ. excl. harmonics (dB)	TBD	TBD	TBD	TBD
ENOB based on SINAD (LSB)	TBD	TBD	TBD	TBD

Certifications and Compliances: EMC Immunity and emission: compliant with CE Mark



ComTec

GmbH · Grünwalder Weg 28a · D-82041 Oberhaching · Germany
Tel 49-(0)89-66 51 80 50 · FAX 49-(0)89-66 51 80 40 · e-mail: info@fastcomtec.com

Ordering Information

M2i.46xx-16 bit high res. A/D converter card, up to 3 MS/s, memory 32MS (64MB), PCI-Bus						
Model					Description	Order No
	1ch	2ch	4ch	8ch		
M2i.4620	200kS	200kS			Input: $\pm(50\text{mV} \dots 10\text{V})$	TR4620
M2i.4621	200kS	200kS	200kS		Input: $\pm(50\text{mV} \dots 10\text{V})$	TR4621
M2i.4622	200kS	200kS	200kS	200kS	Input: $\pm(50\text{mV} \dots 10\text{V})$	TR4622
M2i.4630	500kS	500kS			Input: $\pm(50\text{mV} \dots 10\text{V})$	TR4630
M2i.4631	500kS	500kS	500kS		Input: $\pm(50\text{mV} \dots 10\text{V})$	TR4631
M2i.4632	500kS	500kS	500kS	500kS	Input: $\pm(50\text{mV} \dots 10\text{V})$	TR4632
M2i.4640	1MS	1MS			Input: $\pm(50\text{mV} \dots 10\text{V})$	TR4640
M2i.4641	1MS	1MS	1MS		Input: $\pm(50\text{mV} \dots 10\text{V})$	TR4641
M2i.4642	1MS	1MS	1MS	1MS	Input: $\pm(50\text{mV} \dots 10\text{V})$	TR4642
M2i.4650	3MS	3MS			Input: $\pm(50\text{mV} \dots 10\text{V})$	TR4650
M2i.4651	3MS	3MS	3MS		Input: $\pm(50\text{mV} \dots 10\text{V})$	TR4651
M2i.4652	3MS	3MS	3MS	3MS	Input: $\pm(50\text{mV} \dots 10\text{V})$	TR4652
Drivers M2i.46xx						
M2i.ml					MATLAB driver for all M2i cards	TRml
M2i.46-lv					LabVIEW driver for all M2i.46xx cards	TR46lv
M2i.46-dl					DASYLab driver for all M2i.46xx cards	TR46dl
M2i.46-vee					Agilent VEE driver for all M2i.46xx cards	TR46vee

Memory Expansions M2i.3x, M2i.4x		
Model	Description	Order No
M2i.64MS	Mem. Exp. to 64 MS (128MB) for M2i.3x and M2i.4x series	TR64MS
M2i.128MS	Mem. Exp. to 128 MS (256MB) for M2i.3x and M2i.4x series	TR128MS
M2i.256MS	Mem. Exp. to 256 MS (512MB) for M2i.3x and M2i.4x series	TR256MS
M2i.512MS	Mem. Exp. to 512 MS (1 GB) for M2i.3x and M2i.4x series	TR512MS
M2i.1GS	Mem. Exp. to 1 GS (2 GB) for M2i.3x and M2i.4x series	TR1GS
M2i.2GS	Mem. Exp. to 2 GS (4 GB) for M2i.3x and M2i.4x series	TR2GS

Options		
M2i.mr	Option Multiple Recording	TRmr
M2i.mgt	Option Multiple Recording, Gated Sampling, Timestamp	TRmgt
M2i.mgtab	Option Multiple Recording, Gated Sampling, Timestamp, ABA Modus	TRmgtab
M2i.SH5 (1)	Synchronisation Star-Hub for up to 5 cards, only 1 slot width	TRSH5 (1)
M2i.SH16 (1)	Synchronisation Star-Hub for up to 16 cards, only 1 slot width	TRSH16 (1)
M2i.bxio	Option BaseXIO: 8 digital I/O lines usable as asynchronous I/O, timestamp ref-clock and additional external trigger lines, additional bracket with 8 SMB connectors	TRbxio

Cables for all M2ix boards		
Cab-1m-9m-80	Adapter cable MMCX male to BNC male, 80 cm (for analog inputs)	Cab-1m-9m-80
Cab-1m-9f-80	Adapter cable MMCX male to BNC female, 80 cm (for analog inputs)	Cab-1m-9f-80
Cab-1m-9m-200	Adapter cable MMCX male to BNC male, 200 cm (for analog inputs)	Cab-1m-9m-200
Cab-3f-9m-80	SMB female to BNC male 80cm	Cab-3f-9m-80
Cab-3f-9f-80	SMB female to BNC female 80cm	Cab-3f-9f-80
Cab-3f-3f-80	SMB female to SMB female 80cm	Cab-3f-3f-80
Cab-3f-9m-200	SMB female to BNC male 200cm	Cab-3f-9m-200
Cab-3f-9f-200	SMB female to BNC female 200cm	Cab-3f-9f-200
Cab-3f-3f-200	SMB female to SMB female 200cm	Cab-3f-3f-200
Cab-3f-9f-5	Adapter cable SMB female to BNC female, 5 cm (short cable especially for oscilloscope probes)	Cab-3f-9f-5

Cables for M2i.4x and M2i.3x		
Cab-d40-idx-100	Flat ribbon cable 40 pin FX2 for digital connector to 2x20 pin IDC connector, 100 cm	Cab-d40-idx-100
Cab-d40-d40-100	Flat ribbon cable 40 pin FX2 for digital conn. to 40 pin digital FX2 conn. 100 cm	Cab-d40-d40-100