

M2i.30XX - 40 MS/s to 200 MS/s, 12 bit, PCI-based Transientrecorders



Features:

- PCI-X interface (100% compatible to PCI)
- Fastest 12 bit A/D converter board
- Up to 200 MS/s on one channel, 100 MS/s on two and 60 MS/s on four channels
- Separate ADC and Amplifier per channel
- Simultaneous sampling on all channels
- 6 input ranges: ± 200 mV up to ± 10 V
- 64 MB on-board memory expandable to 4 GB
- Sustained streaming mode to 200 MB/s
- Window, pulse-width, re-arm, OR/AND trigger
- Programmable input offset up-to $\pm 100\%$
- Synchronization option for up-to 16 boards
- ABA mode option: combination of data logging and fast digitizing on trigger
- Software support for Windows and LINUX

Description:

The four models of the M2i.30xx series are designed for the fast and high quality data acquisition. Each of the up to four input channels has its own A/D converter and its own programmable input amplifier. This allows to record signals on all channels with 12 bit resolution without any phase delay between them.

The extremely large on-board memory allows long time recording even with highest sampling rates. A FIFO mode is also integrated on the board. This allows the acquisition of data continuously for online processing in the PC or for data storage on hard disk.

- Completely new developed base card
- 4 GByte memory with one slot width
- Optimized low jitter clock section
- Multi, Gate with programmable pre-, posttrigger and timestamp
- Zero phase delay synchronization
- AND/OR conjunction of trigger/gate

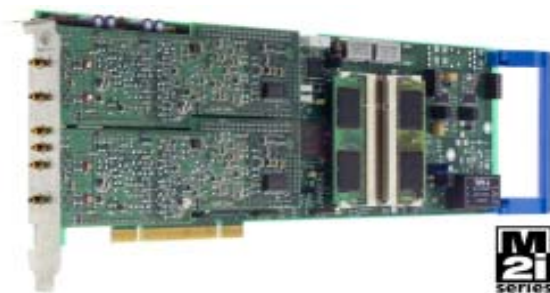

M2i.30xx 23062006

Hardware block diagram

Model	1 channel	2 channels	4 channels
M2i.3010	80 MS/s		
M2i.3011	40 MS/s	40 MS/s	
M2i.3012	80 MS/s	40 MS/s	
M2i.3013	40 MS/s	40 MS/s	40 MS/s
M2i.3014	80 MS/s	80 MS/s	40 MS/s
M2i.3015	160 MS/s	80 MS/s	
M2i.3016	160 MS/s	80 MS/s	40 MS/s
M2i.3020	100 MS/s		
M2i.3021	50 MS/s	50 MS/s	
M2i.3022	100 MS/s	50 MS/s	
M2i.3023	50 MS/s	50 MS/s	50 MS/s
M2i.3024	100 MS/s	100 MS/s	50 MS/s
M2i.3025	200 MS/s	100 MS/s	
M2i.3026	200 MS/s	100 MS/s	50 MS/s
M2i.3027	100 MS/s	100 MS/s	
M2i.3031	60 MS/s	60 MS/s	
M2i.3033	60 MS/s	60 MS/s	60 MS/s

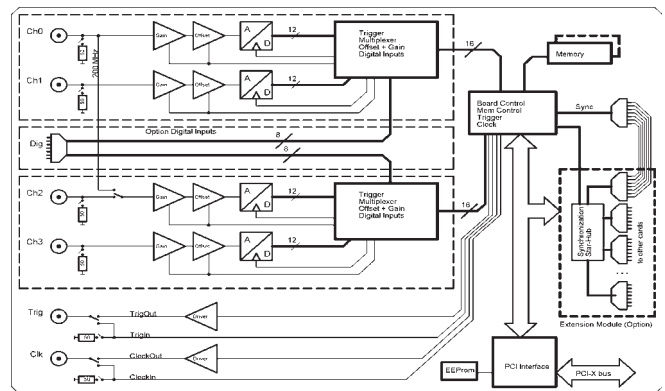

Applications:

- Laser Spectroscopy
- OEM-Applications
- Physics research
- Chemical reaction studies
- LDA/PDA
- RADAR/LIDAR/SONAR
- Telecommunications

Product range overview

All four cards of the M2i.30xx series may use the whole installed on-board memory completely for the currently activated number of channels. See details above

Specifications:

RESOLUTION: 12bit
DIFF. NONLINEARITY: ≤ 1 LSB typ. (ADC)
INTEGRAL NONLINEARITY: ≤ 1 LSB typ. (ADC)
OFFSET ERROR: can be calibrated by the user
GAIN ERROR: $< 1\%$ of current value
PROGRAMMABLE INPUT OFFSET: $\pm 100\%$ of current input range
CROSSTALK 1MHz signa, 50 Ohm trm.: < -70 db between any adjacent channel
INPUT SIGNAL with 50 Ohm termination: max. 5V rms
OVER VOLTAGE PROTECTION $\leq \pm 1V$: $\pm 5V$
OVER VOLTAGE PROTECTION $\geq \pm 1V$: $\pm 50V$
CONNECTOR (analog and trigger/clock): 3mm SMB m

MULTI, GATE, re-arming time: < 4 Samples
MAX PRETRIGGER at MULTI, GATE; FIFO: 8176 samples as sum of all active channels
TRIGGER ACCURACY (≤ 100 MS/s): 1 Sample int.or ext.
TRIGGER ACCURACY (≥ 100 MS/s): 2 Sample int.or ext. trigger mode
CHANNEL TRIGGER RES.: 10 bit
TRIGGER OUTPUT delay: 1 positive edge after internal trigger event
EXT.TRIGGER Accuracy 2/4 channel mode: 1 Sample
EXT.TRIGGER type: TTL compatible
EXT.TRIGGER input: low $\leq 0.8V$, high $\geq 2V$, ≥ 2 clock periods
EXT.TRIGGER max voltage: $-0.5V$ to $+5.5V$
EXT.TRIGGER output levels: TTL comp.
EXT.TRIGGER output: capable of driving a 50 Ohm load

INTERNAL CLOCK accuracy: 20 ppm

INT. CLOCK RANGE: 1 kS/s to max.
INT. CLOCK max. jitter (PPL mode):
INT. CLOCK max. jitter (Quartz mode):
INT. CLOCK set. ($\leq 100M$): $\leq 1\%$ of range (100M, 10M..)
INT. CLOCK set. ($\geq 100M$): fixed value: 160 or 200 MS/s
EXT. CLOCK RANGE: 1 MS/s to max.-see table
EXT. CLOCK DELAY to int. clock: 5.4 ns
EXT. CLOCK INPUT: low $\leq 0.8V$, high $\geq 2V$, duty 45-55%
EXT. CLOCK max. voltage: $-0.5V$ to $+5.5V$
EXT. CLOCK output: low $\leq 0.4V$, high $\geq 2.4V$ (TTL)
EXT. CLOCK output: capable of driving a 50 Ohm load
REF. CLOCK-EXT.CLOCK RANGE: ≥ 4 MHz ≤ 125 MHz

DIMENSION: 312 x 107 mm (full lengths PCI board)
With STAR-HUB 5 / 16: 1 / 2 full size slot
With DIG.INPUTS: 1 full size slot + 1/2 size slot
WEIGHT: from 290g to 460g depending on channels and options (w/o packing)

WARMUP TIME: 10 min
OPERATING TEMP RANGE: 0 to 50 °C
STORAGE TEMP RANGE: -10 to 70 °C
HUMIDITY: 10% to 90%

Please note: The M2i.20x-Series Transientrecorders extensively use SMB connectors. Cables with theses connectors are not included with the boards. They have to be ordered separately if required.



FAST ComTec supports LINUX

Software programmable parameters M2i.30xx		Software programmable parameters M2i.30xx	
Input range	± 200 mV, ± 500 mV, $\pm 1V$, $\pm 2V$, $\pm 5V$ to $\pm 10V$	Trigger mode	Channel, External, SW, Auto, Pulse
Input Impedance	50 Ohm / 1 MOhm (relais)		Window, Re-arm, OR/AND, Delay
Input Offset	$\pm 100\%$ of input range in steps of 1%	Triggerlevel	10 bit res. 1/1024...to full input range
Clock mode	Int. PLL, int. Quartz, ext clock, ext.divided, ext. reference clock, sync	Triggeredge	rising edge, falling edge or both edges
Clock impedance	50 Ohm / high impedance ($> 4k\Omega$)	Trigger pulsewidth	0 to /64k-1) samp. in steps of 1 samp.
Trigger impedance	50 Ohm / high impedance ($> 4k\Omega$)	Trigger delay	0 to /64k-1) samp. in steps of 1 samp.
Memory depth	8 up to (installed memory/active channels in steps of 4)	Post trigger	4 up to (8G-4) samples in steps of 4
Channel selection	Any 1, 2 or 4 channels (see manual for clock limits on the selections)	Multiple Rec. Seq.	8 up to (installed memory/2/active channels in steps of 4)
ABA Clock Driver	1 up to (64-1) in steps of 1	Multi/Gated pretrigger	0 up to (8k samp./active chan.-16) in increments of 32 samples.
		Sync. Clock driver	2 up to (8k-2) in steps of 2

Power Consumption (max speed)	3.3 V	5 V	-12 V	+12 V	Total
M2i.30x0 (32 MS memory)	2.2 A	0.8 A	n.u.	n.u.	11.3 W
M2i.30x1 (32 MS memory)	2.3 A	0.9 A	n.u.	n.u.	12.1 W
M2i.30x5.x7 (32 MS memory)	2.5 A	1.1 A	n.u.	n.u.	13.8 W
M2i.32x3.x4.x6 (32 MS memory)	2.6 A	1.4 A	n.u.	n.u.	15.6 W
M2i.3026 (4 GS) max. power	3.7 A	1.4 A	n.u.	n.u.	19.3 W

Software Support

Windows drivers

The cards are delivered with drivers for Windows 2000, Windows XP, Windows XP64 and Windows Vista (Beta). Programming examples for Visual C/C++, Borland C++ Builder, Gnu C, LabWindows/CVI, Borland Delphi and Visual Basic are included.

Linux Drivers

All cards are delivered with full Linux support. Pre compiled kernel modules are included for the most common distributions like RedHat, Suse or Debian. The linux support is enhanced by SMP support, versatile programming examples as well as the possibility to get the driver sources for own compilation.

SBench

A full licence of SBench the easy-to-use graphical operating software for the Spectrum cards is included in the delivery. The version 6 is running under Windows as well as under Linux (KDE and GNOME)

Third-party products

A lot of third-party products are supported as an option. Choose between LabVIEW, MATLAB, DASyLab and Agilent VEE. All drivers come with examples and detailed documentation.

MI Software compatibility layer

To allow an easy change from MI cards to the new M2i cards for existing software a special software compatibility layer is delivered with the cards. This DLL converts MI calls to M2i calls and simulates a MI card in the software.

Hardware features and options

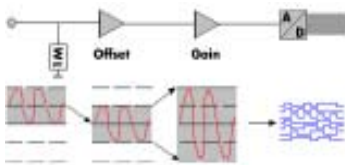

The analog inputs can be adapted to real world signals using a wide variety of settings that are individual for each channel. By using software commands the input termination can be changed between 50 Ohm and 1

MOhm, one can select a matching input range and the signal offset can be compensated for.

Ring buffer mode

Ring buffer mode

The ring buffer mode is the standard mode of all oscilloscope boards. Data is written in a ring memory of the board until a trigger event is detected.

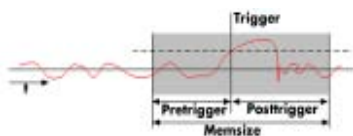

After the event the posttrigger values are recorded. Because of this continuously recording into a ring buffer there are also samples prior to the trigger event visible:

Pretrigger = Memsize - Posttrigger.

FIFO mode

The FIFO mode is designed for continuous data transfer between measurement board and PC memory (up to 225 MB/s on a PCI-X slot and up to 115 MB/s on a PCI slot) or hard disk. The control of the data stream is done automatically by the driver on interrupt request. The

complete installed on-board memory is used for buffer data, making the continuous streaming extremely reliable.

Channel trigger

The data acquisition boards offer a wide variety of trigger modes. Besides the standard signal checking for level and edge as known from oscilloscopes it's also possible to define a window trigger. All trigger modes can be combined with the pulsewidth trigger. This makes it possible to trigger on signal errors like too long or too short pulses. In addition to this a re-arming mode (for accurate trigger recognition on noisy signals) the AND/OR conjunction of different trigger events is possible. As a unique feature it is possible to use deactivated channels as trigger sources.

External trigger I/O

All boards can be triggered using an external TTL signal. It's possible to use positive or negative edge also in combination with a programmable pulse width. An internally recognised trigger event can - when activated by software - be routed to the trigger connector to start external instruments.

Pulse width

Defines the minimum or maximum width that a trigger pulse must have to generate a trigger event. Pulse width can be combined with channel trigger, pattern trigger and external trigger.

Multiple Recording

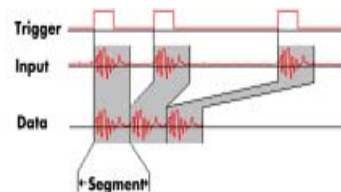

The Multiple Recording option allows the recording of several trigger events with an extremely short re-arming time. The hardware doesn't need to be restarted in between.

The on-board memory is divided into several segments of the same size. Each of them is filled with data if a trigger event occurs. Pre- and posttrigger of the segments can be programmed. The number of acquired segments is only limited by the used memory and is unlimited when using FIFO mode.

Gated Sampling

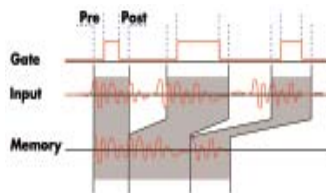

The Gated Sampling option allows data recording controlled by an external gate signal. Data is only recorded if the gate signal has a programmed level. In addition a pre area before start of the gate signal as well as a post area after end of the gate signal can be acquired. The number of gate segments is

only limited by the used memory and is unlimited when using FIFO mode.

Timestamp

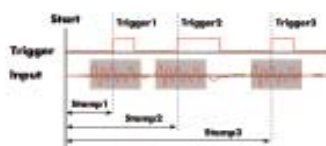

The timestamp option writes the time positions of the trigger events in an extra memory. The timestamps are relative to the start of recording, a defined zero time, externally synchronised to a radio clock, or a GPS receiver.

With this option acquisitions of systems on different locations can be set in a precise time relation.

ABA mode

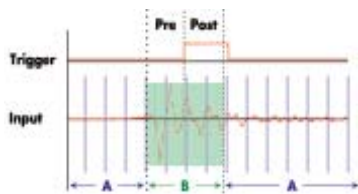

timestamps in an extra memory.

External clock I/O

Using a dedicated connector a sampling clock can be fed in from an external system. It's also possible to output the internally used sampling clock to synchronise external equipment to this clock.

Reference clock



The option to use a precise external reference clock (normally 10 MHz) is necessary to synchronise the board for high-quality mea-

surements with external equipment (like a signal source). It's also possible to enhance the quality of the sampling clock in this way. The driver automatically generates the requested sampling clock from the fed in reference clock.

Star-Hub

The star-hub is an additional module allowing the phase stable synchronisation of up to 16 boards. Independent of the number of boards there is no phase delay between all channels. The star-hub distributes trigger and clock information between all boards. As a result all connected boards are running with the same clock and the same trigger. All trigger sources can be combined with OR/AND allowing all channels of all cards to be trigger source at the same time. The star-hub is available as 5 card and 16 card version. The 5 card version doesn't need an extra slot.



	M21.3011 M21.3013	M21.3021 M21.3023	M21.3031 M21.3033	M21.3010 M21.3012 M21.3014	M21.3020 M21.3022 M21.3024 M21.3027	M21.3015 M21.3016	M21.3025 M21.3026
Dynamic Parameters							
Max internal clock	40 MS/s	50 MS/s	62.5 MS/s	80 MS/s	105 MS/s	160 MS/s	200 MS/s
Max external clock	40 MS/s	50 MS/s	62.5 MS/s	80 MS/s	105 MS/s	80 MS/s	105 MS/s
-3 dB bandwidth	DC..20 MHz	DC..25 MHz	DC..30 MHz	DC..40 MHz	DC..40 MHz	DC..40 MHz	DC..40 MHz
Zero noise level (<125 MS/s)	<1.1 LSB rms	<1.1 LSB rms			<1.2 LSB rms		
Zero noise level (>125 MS/s)							
Test Rate for SNR, THD, SFDR, ENOB	40 MS/s	50 MS/s	60 MS/s	80 MS/s	100 MS/s	80 MS/s	100 MS/s
Test signal frequency	1 / 4 MHz	1 / 4 MHz	1 / 4 MHz	1 / 9 MHz	1 / 9 MHz	1 / 9 MHz	1 / 9 MHz
SNR typ. (dB)	66.2 / 64.8	65.8 / 64.5			65.5 / 64.0		
THD typ. (dB)	-72.0 / -71.0	-72.0 / -71.0			-72.0 / -66.1		
SFDR typ. excl. harmonics (dB)	80.8 / 78.9	80.2 / 78			78.0 / 77.5		
ENOB based on SNR (LSB)	10.7 / 10.4	10.7 / 10.4			10.6 / 10.3		
ENOB based on SINAD (LSB)	10.6 / 10.2	10.6 / 10.2			10.4 / 10.1		

Certifications and Compliances: EMC Immunity and emission: compliant with CE Mark



ComTec

GmbH · Grünwalder Weg 28a · D-82041 Oberhaching · Germany
Tel 49-(0)89-66 51 80 50 · FAX 49-(0)89-66 51 80 40 · e-mail: info@fastcomtec.com

Ordering Information

F2i.30xx - 12 bit transient recorder with up to 200 MS/s, onboard memory 32 MS (64 MB), PCI-Bus					
Model				Description	Order No
	1ch	2ch	4ch		
M2i.3010	80 MS/s			Input: $\pm(200\text{mV} \dots 10\text{V})$	TR3010
M2i.3011	40 MS/s	40 MS/s		Input: $\pm(200\text{mV} \dots 10\text{V})$	TR3011
M2i.3012	80 MS/s	40 MS/s		Input: $\pm(200\text{mV} \dots 10\text{V})$	TR3012
M2i.3013	40 MS/s	40 MS/s	40 MS/s	Input: $\pm(200\text{mV} \dots 10\text{V})$	TR3013
M2i.3014	80 MS/s	80 MS/s	40 MS/s	Input: $\pm(200\text{mV} \dots 10\text{V})$	TR3014
M2i.3015	160 MS/s	80 MS/s		Input: $\pm(200\text{mV} \dots 10\text{V})$	TR3015
M2i.3016	160 MS/s	80 MS/s	40 MS/s	Input: $\pm(200\text{mV} \dots 10\text{V})$	TR3016
M2i.3020	100 MS/s			Input: $\pm(200\text{mV} \dots 10\text{V})$	TR3020
M2i.3021	50 MS/s	50 MS/s		Input: $\pm(200\text{mV} \dots 10\text{V})$	TR3021
M2i.3022	100 MS/s	50 MS/s		Input: $\pm(200\text{mV} \dots 10\text{V})$	TR3022
M2i.3023	50 MS/s	50 MS/s	50 MS/s	Input: $\pm(200\text{mV} \dots 10\text{V})$	TR3023
M2i.3024	100 MS/s	100 MS/s	50 MS/s	Input: $\pm(200\text{mV} \dots 10\text{V})$	TR3024
M2i.3025	200 MS/s	100 MS/s		Input: $\pm(200\text{mV} \dots 10\text{V})$	TR3025
M2i.3026	200 MS/s	100 MS/s	50 MS/s	Input: $\pm(200\text{mV} \dots 10\text{V})$	TR3026
M2i.3027	100 MS/s	100 MS/s		Input: $\pm(200\text{mV} \dots 10\text{V})$	TR3027
M2i.3031	60 MS/s	60 MS/s		Input: $\pm(200\text{mV} \dots 10\text{V})$	TR3031
M2i.3033	60 MS/s	60 MS/s	60 MS/s	Input: $\pm(200\text{mV} \dots 10\text{V})$	TR3033
Drivers M2i.30x					
M2i.ml				MATLAB driver for all M2i cards	TRml
M2i.30-lv				LabVIEW driver for all M2i.30xx cards	TR30lv
M2i.30-dl				DASyLab driver for all M2i.30xx cards	TR30dl
M2i.30-vee				Agilent VEE driver for all M2i.30xx cards	TR30vee

Memory Expansions M2i.3x, M2i.4x		
Model	Description	Order No
M2i.64MS	Mem. Exp. to 64 MS (128MB) for M2i.3x and M2i.4x series	TR64MS
M2i.128MS	Mem. Exp. to 128 MS (256MB) for M2i.3x and M2i.4x series	TR128MS
M2i.256MS	Mem. Exp. to 256 MS (512MB) for M2i.3x and M2i.4x series	TR256MS
M2i.512MS	Mem. Exp. to 512 MS (1 GB) for M2i.3x and M2i.4x series	TR512MS
M2i.1GS	Mem. Exp. to 1 GS (2 GB) for M2i.3x and M2i.4x series	TR1GS
M2i.2GS	Mem. Exp. to 2 GS (4 GB) for M2i.3x and M2i.4x series	TR2GS
Options		
M2i.mr	Option Multiple Recording	TRmr
M2i.mgt	Option Multiple Recording, Gated Sampling, Timestamp	TRmgt
M2i.mgtab	Option Multiple Recording, Gated Sampling, Timestamp, ABA Modus	TRmgtab
M2i.SH5 (1)	Synchronisation Star-Hub for up to 5 cards, only 1 slot width	TRSH5 (1)
M2i.SH16 (1)	Synchronisation Star-Hub for up to 16 cards, only 1 slot width	TRSH16 (1)
M2i.bxio	Option BaseXIO: 8 digital I/O lines usable as asynchronous I/O, timestamp ref-clock and additional external trigger lines, additional bracket with 8 SMB connectors	TRbxio
Options for M2i.3x		
M2i.3-dig	Additional synchronous digital inputs (4 per analog channel) including Cab-d40-idc-100	TR3dig
Cables for all M2ix boards		
Cab-1m-9m-80	Adapter cable MMCX male to BNC male, 80 cm (for analog inputs)	Cab-1m-9m-80
Cab-1m-9f-80	Adapter cable MMCX male to BNC female, 80 cm (for analog inputs)	Cab-1m-9f-80
Cab-1m-9m-200	Adapter cable MMCX male to BNC male, 200 cm (for analog inputs)	Cab-1m-9m-200
Cab-3f-9m-80	SMB female to BNC male 80cm	Cab-3f-9m-80
Cab-3f-9f-80	SMB female to BNC female 80cm	Cab-3f-9f-80
Cab-3f-3f-80	SMB female to SMB female 80cm	Cab-3f-3f-80
Cab-3f-9m-200	SMB female to BNC male 200cm	Cab-3f-9m-200
Cab-3f-9f-200	SMB female to BNC female 200cm	Cab-3f-9f-200
Cab-3f-3f-200	SMB female to SMB female 200cm	Cab-3f-3f-200
Cab-3f-9f-5	Adapter cable SMB female to BNC female, 5 cm (short cable especially for oscilloscope probes)	Cab-3f-9f-5
Cables for M2i.4x and M2i.3x		
Cab-d40-idc-100	Flat ribbon cable 40 pin FX2 for digital connector to 2x20 pin IDC connector, 100 cm	Cab-d40-idc-100
Cab-d40-d40-100	Flat ribbon cable 40 pin FX2 for digital connector to 40 pin digital FX2 connector, 100 cm	Cab-d40-d40-100