

PC250 Test Board for the A250

The PC250 is a printed circuit board designed to facilitate testing of the A250. Ground plane construction minimizes external pick-up.

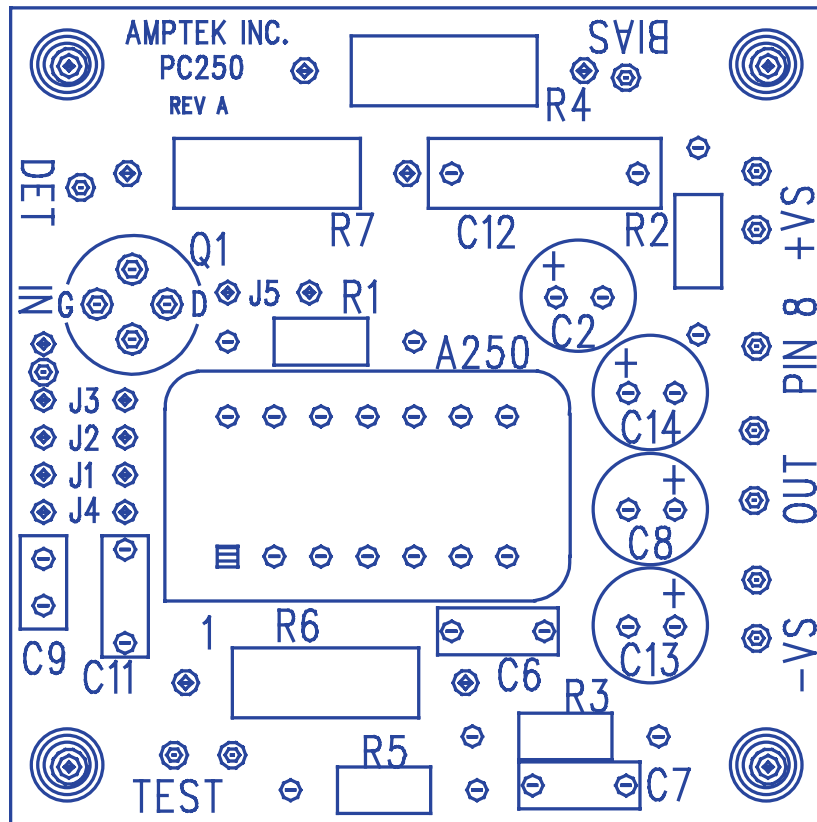

Dimensions: 1.75 in x 1.75 in (4.5 cm x 4.5 cm)
Material: Teflon

Amptek Inc. 6 De Angelo Drive, Bedford, MA 01730-2204 USA

Tel: +1 781 275-2242 Fax: +1 781 275-3470 Email: sales@amptek.com <http://www.amptek.com>

PC250 Wiring Diagram for the A250

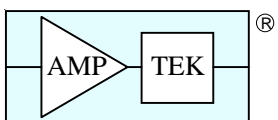
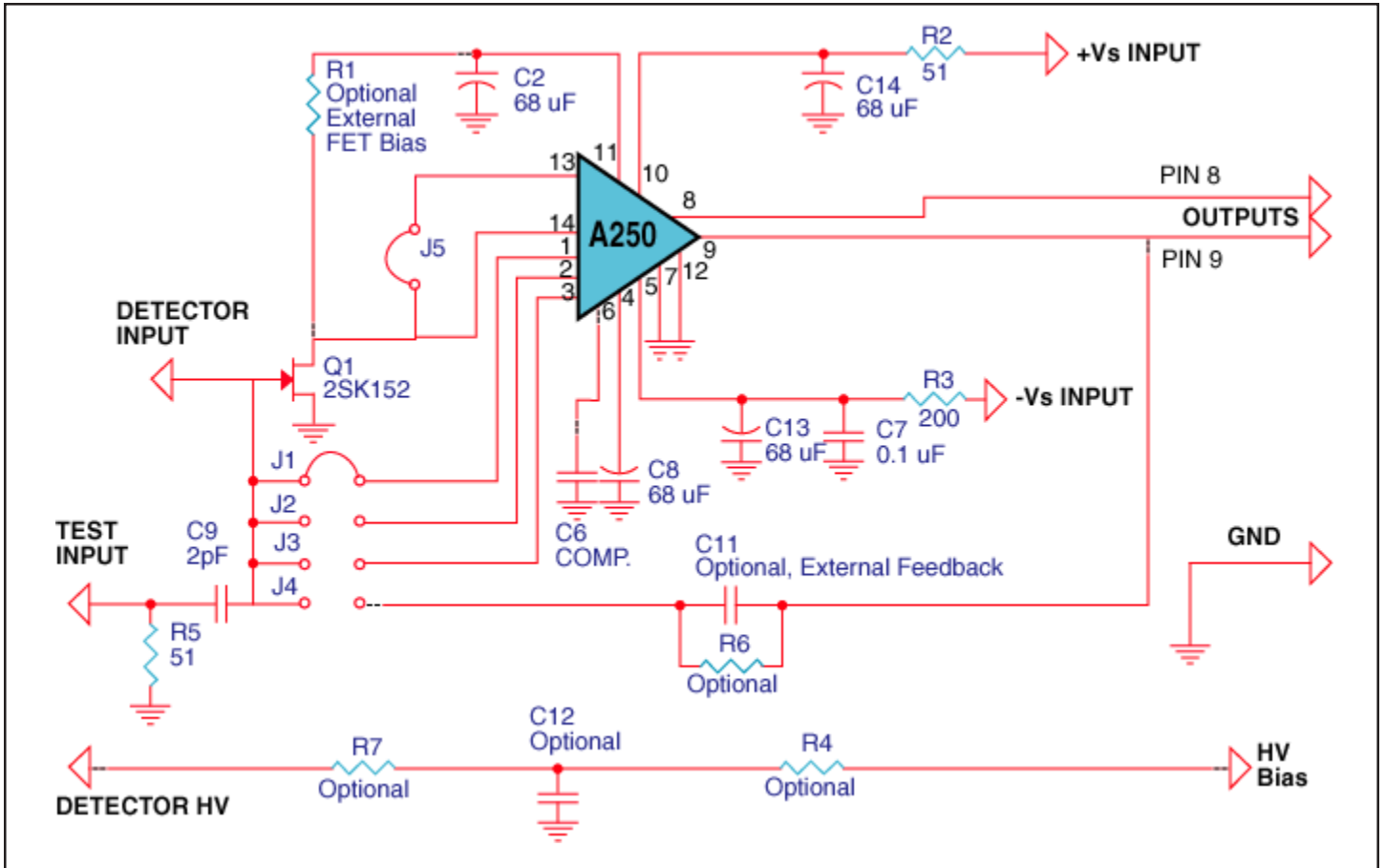

Amptek Inc. 6 De Angelo Drive, Bedford, MA 01730-2204 USA

Tel: +1 781 275-2242 Fax: +1 781 275-3470 Email: sales@amptek.com <http://www.amptek.com>