

## X-RAY and GAMMA RAY DETECTOR HIGH RESOLUTION CdTe CADMIUM TELLURIDE

# XR-100T-CdTe

*DETECTOR TECHNOLOGY ADVANCEMENT - The XR-100T-CdTe provides "off the shelf" performance previously available only from expensive cryogenically cooled systems.*

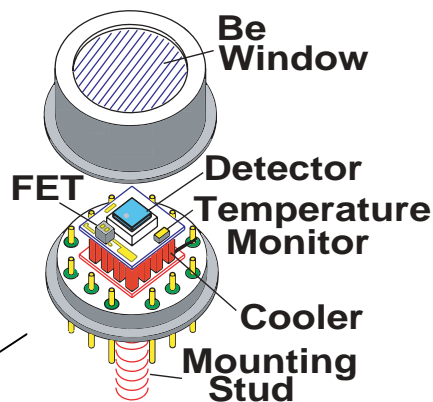

### APPLICATIONS:

- Medical X-Ray & Gamma Ray Detection
- Mammography, Radiology & Conventional X-Ray
- Uranium & Plutonium Detection
- Portable X-Ray & Gamma Ray Instruments
- Research & Teaching
- Nuclear Plant Monitoring
- X-Ray Fluorescence
- Art & Archaeology

### FEATURES:

- CdTe-Diode Detector
- Thermoelectric (Peltier) Cooler
- Cooled FET
- Beryllium Window
- Temperature Monitor
- Hermetic Detector Package
- Wide Detection Range
- Amptek A250 Preamp

Model **XR-100T-CdTe** is a new high performance X-Ray and Gamma Ray Detector, Preamplifier, and Cooler system using a 3 x 3 x 1 mm<sup>3</sup> Cadmium Telluride (CdTe) diode detector mounted on a thermoelectric cooler. Also, on the cooler are mounted the input FET and feedback components to the Amptek A250 charge sensitive preamp. The internal components are kept at approximately -30°C, and can be monitored by a temperature sensitive integrated circuit. The hermetic TO-8 package of the detector has a light tight, vacuum tight 10 mil (250 μm) Beryllium window.

All the critical connections between the detector and preamplifier have been made internally to the XR-100T-CdTe to ensure quick, first time operation by the user. The XR-100T-CdTe is provided complete with BNC connectors and power cable.

In order to facilitate the use of the detector, Model PX2T was developed to provide the DC Voltages needed to operate the XR-100T-CdTe, and the signal processing through the Shaping Amplifier and Rise Time Discrimination (RTD) circuits. The signal output from the PX2T can be connected directly to a Multichannel Analyzer (MCA).

The XR-100T-CdTe is capable of detecting energies from a few keV to several hundreds of keV.

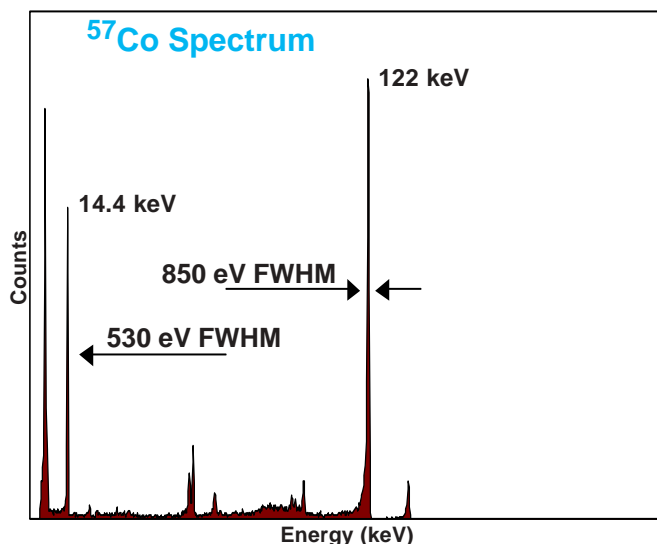

**AMPTEK INC.** 6 De Angelo Drive, Bedford, MA 01730-2204 U.S.A.

**Tel:** +1 (781) 275-2242 **Fax:** +1 (781) 275-3470 **email:** sales@amptek.com <http://www.amptek.com>

## THEORY OF OPERATION

X-Rays and Gamma Rays interact with CdTe atoms to create an average of one electron/hole pair for every 4.43 eV of energy lost in the CdTe. Depending on the energy of the incoming radiation, this energy loss is dominated by either the Photoelectric Effect or Compton Scattering. The probability or efficiency of the detector to “stop” the incoming radiation and create electron/hole pairs increases with the thickness of CdTe. See Figure 2.

In order to facilitate the electron/hole collection process in the CdTe detector, a 400 Volt potential is applied. This voltage is too high for operation at room temperature, as it will cause excessive leakage, and eventually a breakdown. Since the detector in the XR-100T-CdTe is cooled, the leakage current is reduced considerably, thus permitting the high bias voltage.

Electron/hole pairs created by radiation, which interacts with the CdTe near the back contact of the detector, result in fluctuations of charge collection times. These fluctuations are observed as rise time variations of the voltage step at the output of the charge sensitive preamplifier. As a result, the acquired spectra suffer from increase background counts and degraded energy resolution. To reduce these effects a Rise Time Discrimination (RTD) circuit has been developed for the PX2T amplifier. When the RTD is active, the shaped pulses are internally gated and only pulses corresponding to “full charge collection” events are allowed to be sent to the Multichannel Analyzer (MCA) for analysis. See Figure 1.

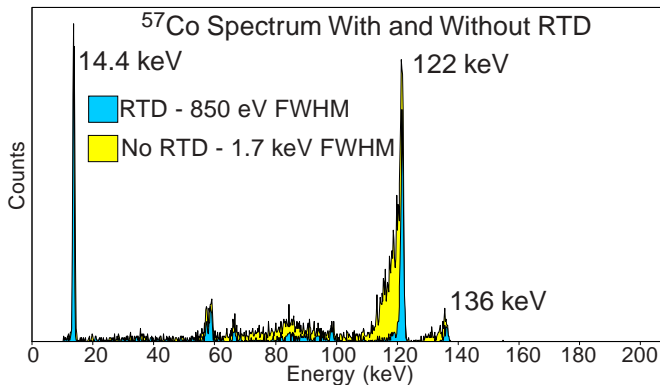

FIGURE 1. Comparison With and Without RTD

The thermoelectric cooler cools both the CdTe detector and the input FET transistor to the A250 Charge Sensitive Preamplifier. Cooling the FET reduces its leakage current and increases the transconductance, which in turn reduce the electronic noise of the system.

In order to further reduce the electronic noise, the feedback capacitor and part of the current feedback network to the A250 preamp are also placed on the same substrate as the detector and FET. This minimizes parasitic capacitance at the input.

A temperature monitoring integrated circuit is placed on the cooled substrate to provide a direct reading of the temperature of the internal components, which will vary with room temperature. Once the internal temperature gets below minus 10°C the performance of the XR-100T-CdTe will not change with a temperature variation of a few degrees. Hence, accurate temperature control is not necessary when using the XR-100T-CdTe inside the laboratory.

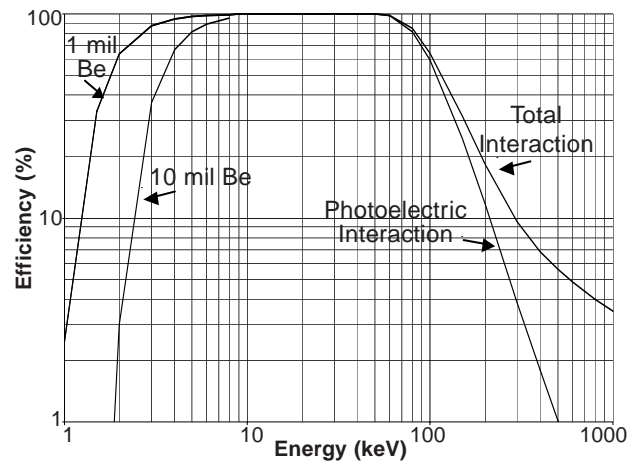

FIGURE 2. 1 mm Thick CdTe Detection Efficiency

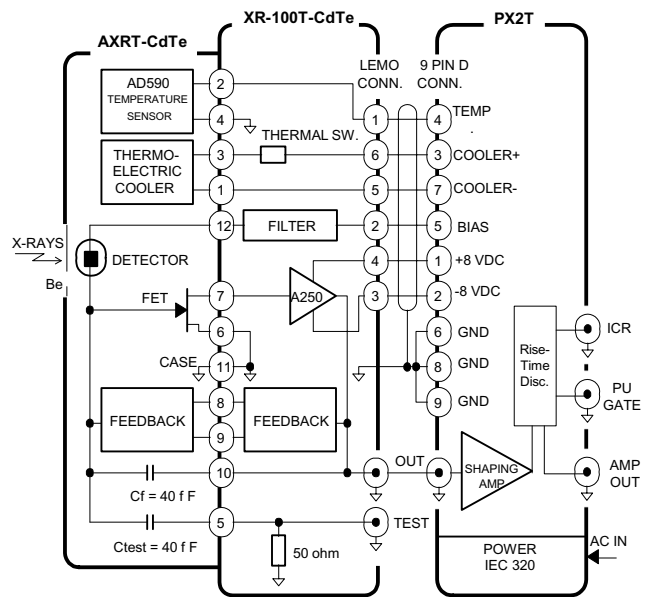

FIGURE 3. XR-100T-CdTe CONNECTION DIAGRAM  
This diagram shows the internal connections between the AXRT-CdTe hybrid sensor and the electronics with the case, as well as the external connections to the PX2T.

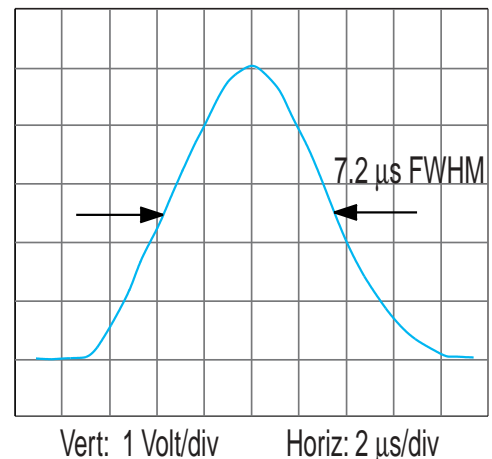

FIGURE 4. PX2T AMPLIFIER OUTPUT

# SPECIFICATIONS

## MODEL XR-100T-CdTe X-RAY and GAMMA RAY DETECTOR

### GENERAL

Detector Type:	CdTe-Diode
Detector Size:	3 x 3 mm (9 mm <sup>2</sup> )
Detector Thickness:	1 mm
Energy Resolution @ 122 keV, <sup>57</sup> Co:	<1.2 keV FWHM, typical
Dark Counts:	<5 x 10 <sup>-3</sup> counts/sec @ 10 keV < E < 1 MeV
Detector Window:	Be, 10 mil thick (250 μm)
Preamplifier:	Amptek Model A250, with Current Divider Feedback
Case Size:	3.75 x 1.75 x 1.13 in (9.5 x 4.4 x 2.9 cm)
Case Weight:	4.4 ounces (125 g)
Total Power:	Less than 1 Watt

### INPUTS

Test Input:	20 mV test pulse ~ 30 keV
Preamp Power:	± 8 Volts @ 25 mA
Detector Power:	+ 400 Volts @ 1 μA
Cooler Power:	Current = 0.7 A maximum Voltage = 2.1 Volt maximum

### OUTPUTS

1) Preamplifier	
Sensitivity:	0.82 mV/keV
Polarity:	Negative Signal Out (1 kΩ max. load)
2) Temperature Monitor	
Sensitivity:	1 μA corresponds to 1 °K

### CONNECTIONS

Preamp Output:	BNC coaxial connector
Test Input:	BNC coaxial connector
Other connections:	6-Pin, LEMO connector with 5 ft cable

### OPTIONS

- Other detector sizes (5 x 5 x 1 mm<sup>3</sup>) are available on special orders.
- Other Be window thicknesses are available.
- Components for vacuum applications.
- Collimator kit for high flux applications.
- See also XR-100CR specifications using Si-PIN for detection of low energy X-Rays with high resolution (186 eV FWHM @ 5.9 keV, <sup>55</sup>Fe).

### 6-PIN LEMO CONNECTOR ON THE XR-100T-CdTe

Pin 1:	+8 Volt temperature monitor power
Pin 2:	+ H.V. detector bias, +400 Volt max.
Pin 3:	-8 Volt preamp power
Pin 4:	+8 Volt preamp power
Pin 5:	Cooler power return
Pin 6:	Cooler power (0 to +2.1 Volt @ 0.7 A max.)
CASE:	Ground and shield

## MODEL PX2T POWER SUPPLY + SHAPING AMPLIFIER

### GENERAL

Size:	6 X 6 X 3.5 inches (15.3 X 15.3 X 8.9 cm)
Weight:	2.5 lbs (1.15 kg)

Input AC power to the PX2T is provided through a Standard IEC 320 plug (110/250 VAC, 50/60 Hz). See Figure 3.

The four (4) DC Voltages needed to operate the XR-100T-CdTe are supplied through a female 9-Pin D-Connector on the PX2T. The Pin list to this connector is given below. The multiconductor cable which connects the PX2T to the XR-100T-CdTe is provided with the system.

### 9-PIN D-CONNECTOR ON THE PX2T-CZT

Pin 1:	+8 Volt preamp power
Pin 2:	-8 Volt preamp power
Pin 3:	0 to +3 Volt cooler power @ 0.7 A max.
Pin 4:	+8 Volt temperature monitor power
Pin 5:	+ H.V. detector bias, +400 Volt max.
Pin 6:	Ground and case
Pin 7:	Cooler power return
Pin 8:	Ground and case
Pin 9:	Ground and case

### PX2T SHAPING AMPLIFIER

Polarity:	Positive Unipolar
Shaping Time:	3 μs
Pulse Width:	7.2 μs FWHM. See Figure 4
Shaping Type:	7 pole "Triangular" with Base Line Restoration, Pileup Rejection, and Rise Time Discrimination (RTD).

Sensitivity with XR-100T-CdTe:	6 to 60 mV/keV
Output Range:	+6.0 Volts into 500 Ω load
Output Impedance:	50 Ω

The output pulse produced by the PX2T Shaping Amplifier is optimum for most applications using cooled CdTe detectors, and can be connected directly to the input of a Multichannel Analyzer (MCA). If different shaping time constants or gains are needed, an external NIM type shaping amplifier with base line restoration can be used.

### PX2T SIGNAL CONNECTIONS

Input from XR-100T-CdTe:	Front panel BNC
Output to MCA:	Front panel BNC
Pileup Rejection (PU):	Rear panel BNC, Positive TTL For the duration of this output gate, any detected pulse must be rejected by the MCA.
Input Count Rate (ICR):	Rear panel BNC, Positive TTL <2 μs When connected to a counter, the ICR countrate corresponds to the total number of X-Rays events that strike the detector.

# XR-100T-CdTe TYPICAL PERFORMANCE

All spectra below were taken with a 3 x 3 x 1 mm thick CdTe-diode detector *with* the use of RTD.

All the spectra are taken with the Amptek MCA8000A multichannel analyzer.

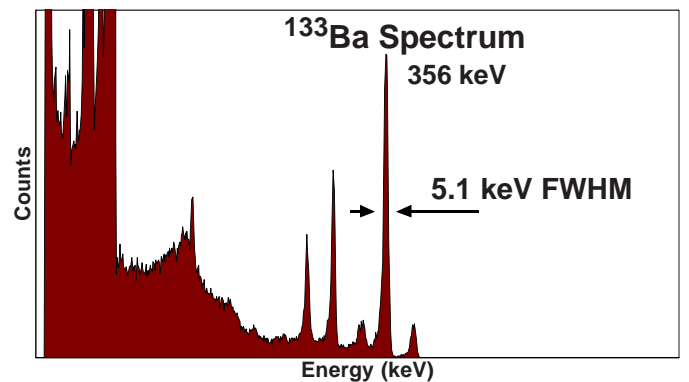
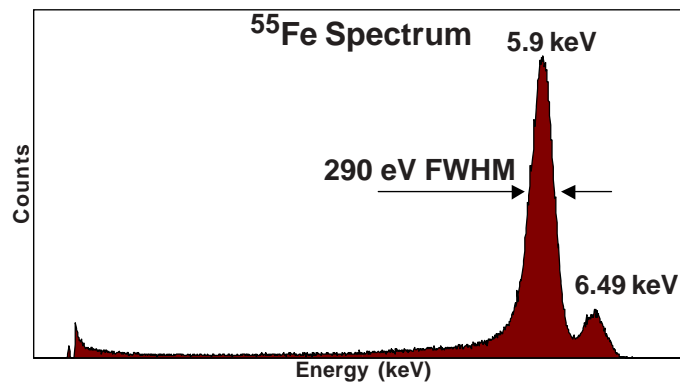
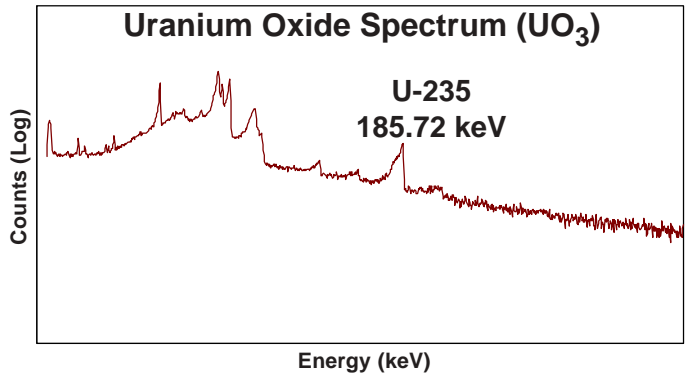
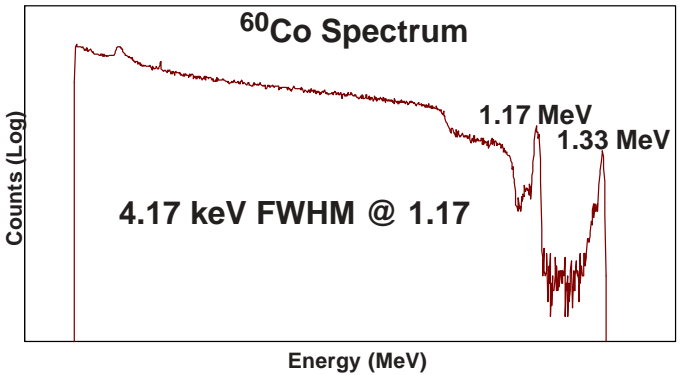
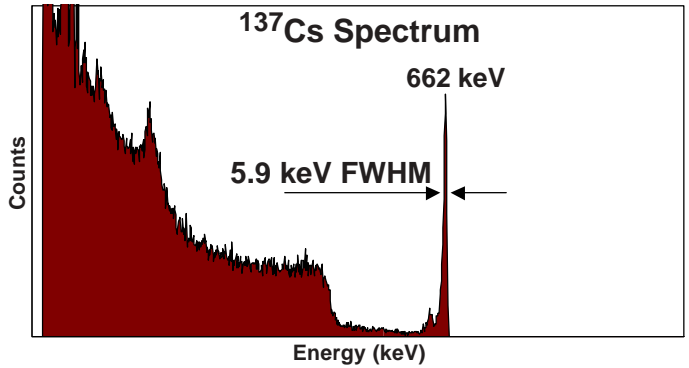
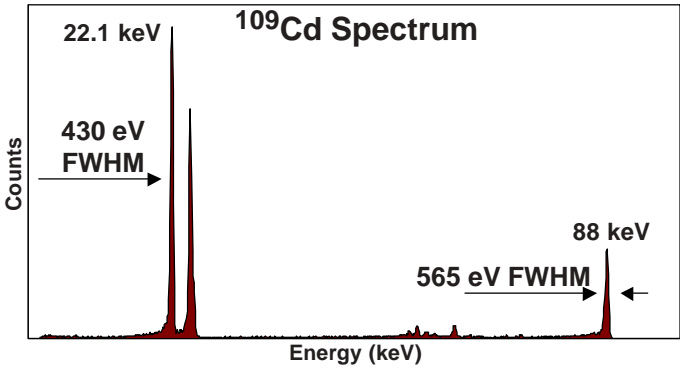
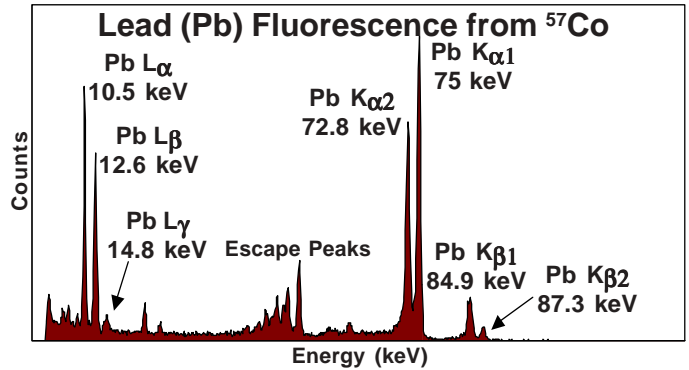
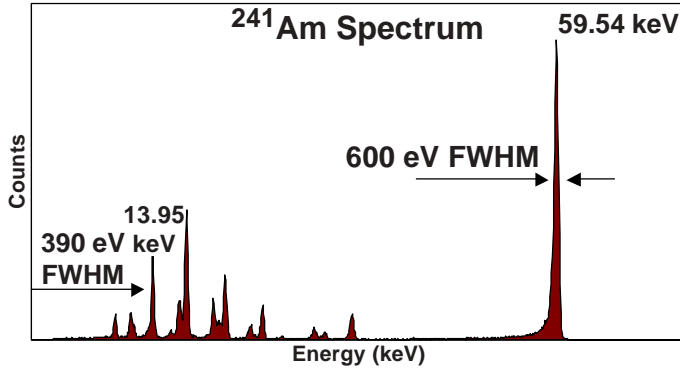

**AMPTEK INC.**

6 De Angelo Drive

Bedford, MA 01730-2204 U.S.A.

Tel: +1 (781) 275-2242 Fax: +1 (781) 275-3470

email: sales@amptek.com http://www.amptek.com

In Germany, Switzerland and Austria contact

**FAST ComTec**

FAST ComTec (www.fastcomtec.com)

Phone: +49-89-665180-50 FAX: +49-89-665180-40

e-mail: info@fastcomtec.com