

GFT 632

32V Output Module for Model 745



FEATURES

- Output pulse 32V amplitude under 50Ω, < 3ns rise time
- 1μs Width, < 2 ps RMS jitter
- External Trigger Input
- Operate from standard 12V AC/DC adapter
- Options 15 to 70 V amplitude, 50 ns to 1 μs width

APPLICATIONS

- Components Test
- ATE Application
- Precision Pulse Application

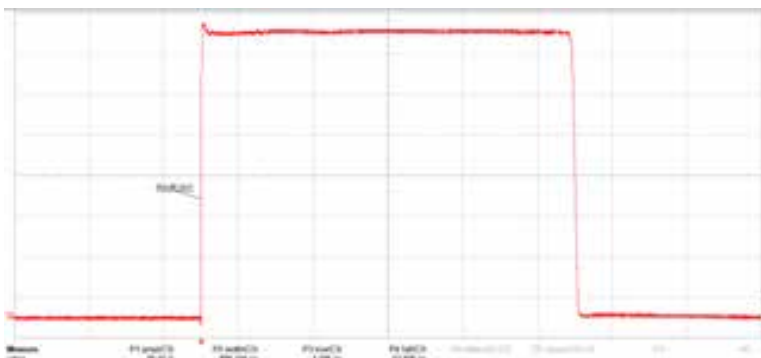

(10V/div, 200ns/div)
Amplitude = 70V width=1μs
Tr=1.2ns, Tf=14ns

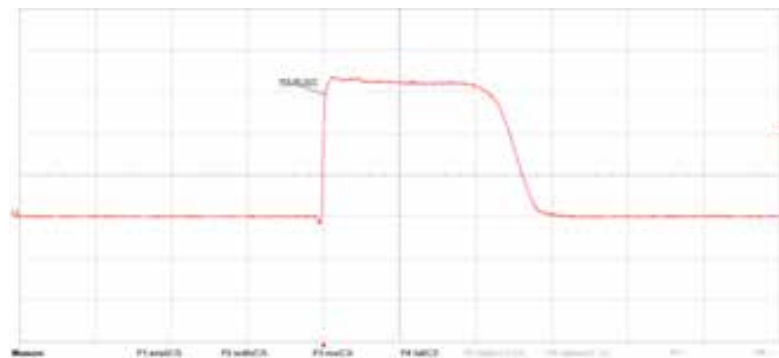

10V/div, 20ns/div
Amplitude = 32V, width= 50ns
Tr=1ns, Tf=11ns



Berkeley Nucleonics

Test, Measurement and Nuclear Instrumentation since 1963

Output Module for Model 745

Module Description

The externally triggered module is a pulse generator up to 70V. This compact module produces square pulses up to 70V into 50 Ω with fast 2ns rise time.

The output amplitude is factory adjusted from 15V to 70V. The output width is also factory adjusted from 50ns to 1μs.

Typical applications include amplifying the output of the BNC Model 745 digital delay generator. The module can be up to 20 meters from the DDG and nearer the device to be trigger.

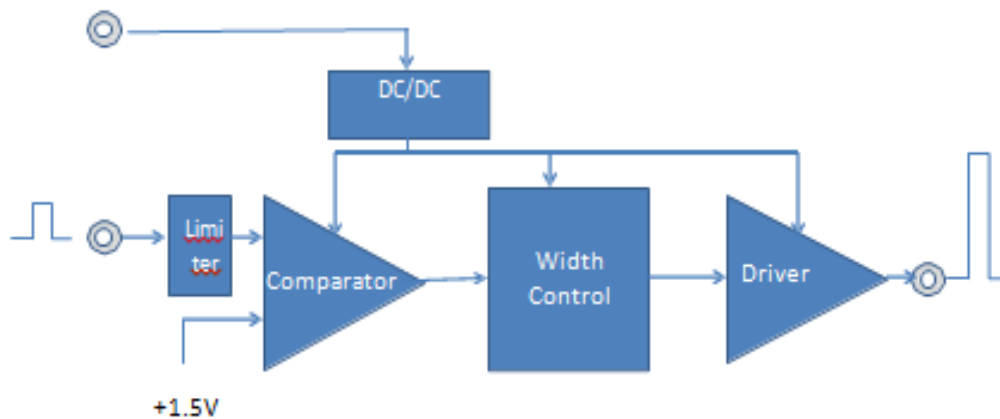

Specifications:

Input		Output	
Amplitude	Positive > 2 V	Pulse shape	Rectangular
Internal impedance	50 Ω	Amplitude	32 V +/- 0.5 V
Rise time	< 5 ns	External load	50 Ω
Threshold	+ 1.5 V	Rise time	< 2 ns
Width	> 10 ns	Fall time	< 15 ns
Repetitive rate	10 KHz (max.)	Width (FWHM)	1 μs +/- 5%
Connector	BNC	Insertion Delay	< 5 ns
General		Options	
Size	106.0 x 38.5 x 31.6 mm	Amplitude 15 to 70 V	
Power V/A	12 V / 200 mA max.	Width 50 ns to 1 μs	
Connector	Locking Power Jack		
Leds	Green (power), yellow (trigger)		
External AC/DC adapter for power supply + 12 V			