

TOTAL VOLUME GAMMA RAY DETECTOR

XR-100T-CdTe- Stack

STACK of CdTe-DIODE DETECTORS *Advanced Product Information*



APPLICATIONS:

- Uranium & Plutonium Detection
- Portable X-Ray & Gamma Ray Instruments
- Nuclear Plant Monitoring
- Medical X-Ray & Gamma Ray Detection
- Mammography, Radiology & Conventional X-Ray
- Research & Teaching
- X-Ray Fluorescence
- Art & Archaeology

FEATURES:

- 3 CdTe-Diode Detectors
- Thermoelectric (Peltier) Cooler
- Cooled FET
- No Rise Time Discrimination (RTD) needed
- Beryllium Window
- Temperature Monitor
- Hermetic Detector Package
- 1000 Volts (typical) Bias on each detector

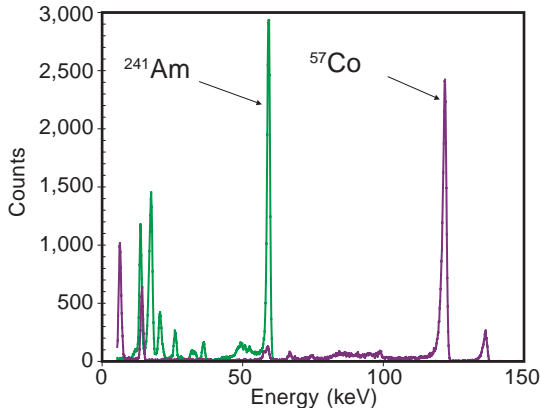

Figure 1. ²⁴¹Am and ⁵⁷Co Spectrum

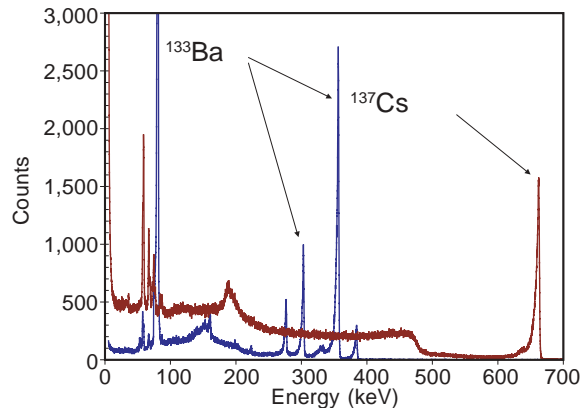

Figure 2. ¹³³Ba and ¹³⁷Cs Spectrum

Model **XR-100T-CdTe-Stack** is a new high performance X-Ray and Gamma Ray Detector, Preamplifier, and Cooler system using a stack of three 5 x 5 x 0.75 mm³ Cadmium Telluride (CdTe) diode detectors mounted on a thermoelectric cooler. Also on the cooler are the input FET and feedback components to the charge sensitive preamp. The internal components are kept at approximately -30°C, and can be monitored by a temperature sensitive integrated circuit. The hermetic TO-8 package of the detector has a light tight, vacuum tight 10 mil (250 µm) Beryllium window. All the critical connections between the detector and preamplifier have been made internally to the XR-100T-CdTe-Stack to ensure quick, first time operation by the user. The XR-100T-CdTe-Stack is provided complete with BNC connectors and power cable.

In order to facilitate the use of the detector, model PX4 was developed to provide a shaping amplifier using digital pulse processing technology; integrated multichannel analyzer, and power supplies.

AMPTEK INC. 6 De Angelo Drive, Bedford, MA 01730-2204 U.S.A.

Tel: +1 (781) 275-2242 **Fax:** +1 (781) 275-3470 **email:** sales@amptek.com <http://www.amptek.com>

THEORY OF OPERATION

X-Rays and Gamma Rays interact with CdTe atoms to create an average of one electron/hole pair for every 4.43 eV of energy lost in the CdTe. Depending on the energy of the incoming radiation, this energy loss is dominated by either the photoelectric effect or Compton scattering. The probability or efficiency of the detector to “stop” the incoming radiation and create electron/hole pairs increases with the thickness of CdTe. See Figure 4.

In order to facilitate the electron/hole collection process in the CdTe-diode detector, a bias of up to 1500 Volts is applied. This voltage is too high for operation at room temperature, as it will cause excessive leakage and eventually a breakdown. Since the detectors in the XR-100T-CdTe-Stack are cooled, the leakage current is reduced considerably, thus permitting the high bias voltage.

To efficiently detect gamma rays with energies of hundreds of keV, Amptek has developed a “stack” detector, using multiple detector elements, each 0.75 mm thick and 25 mm² area. The detector stack is mounted on a thermoelectric cooler and packaged using Amptek’s successful XR-100 technology.

The advantage of this detector stack over a single detector of the same volume is the significant improvement in charge transport. The charges are transported across 0.75 mm, so the hole tailing is equal to that seen with a single 0.75 mm thick detector, but for radiation interaction purposes, the entire volume is used. Charge collection efficiency is much higher than in a single, planar element of equal volume since the travel distance to the collecting electrode is short.

The intrinsic efficiency of the stacked detectors was measured by comparison with a 1" NaI detector. The intrinsic efficiency was measured to be within 1% of that computed from the volume of the detector, implying that the full volume is used and contributes to the photopeak. See Figures 5 and 6.

The thermoelectric cooler cools both the CdTe-diode detectors and the input FET transistor to the charge sensitive preamplifier. Cooling the FET reduces its leakage current and increases the transconductance, which in turn reduce the electronic noise of the system.

In order to further reduce the electronic noise, the feedback capacitor and part of the current feedback network to the preamplifier are also placed on the same substrate as the detector and FET. This minimizes parasitic capacitance at the input.

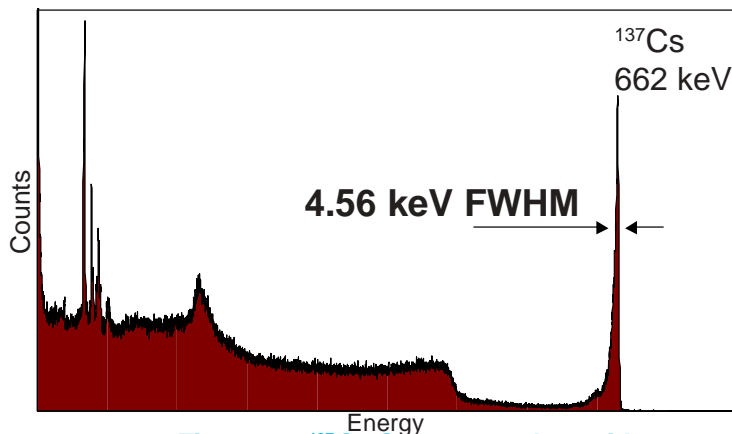

Figure 3. ¹³⁷Cs Spectrum taken with Stack of 3 Detectors

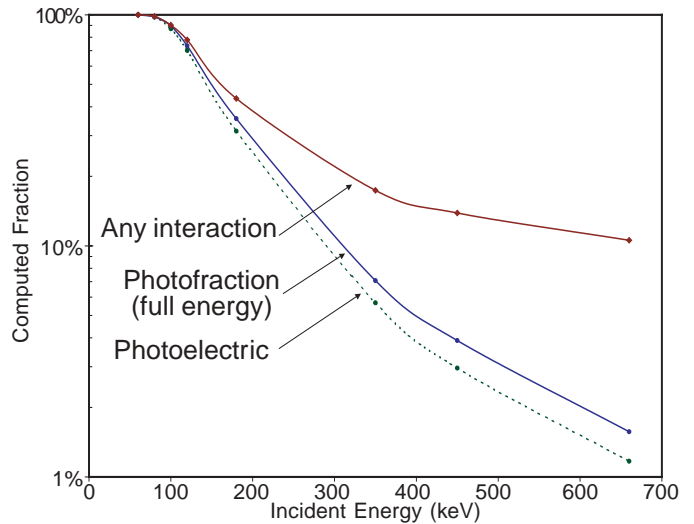

Figure 4. Computed Interaction Probability 5 x 5 x 2.25 mm³ CdTe

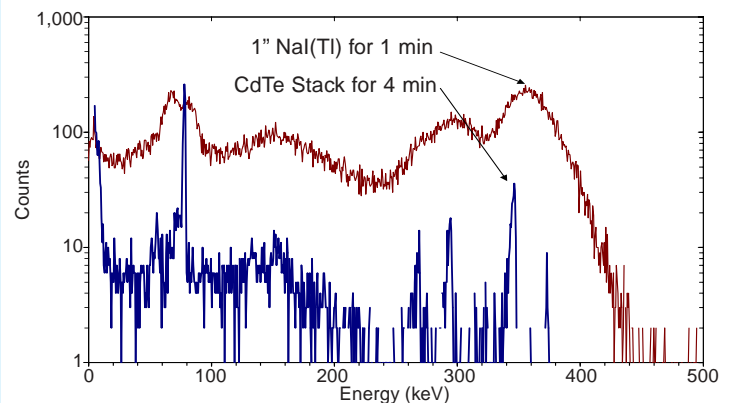

Figure 5. CdTe Stack and NaI(Tl) Comparison

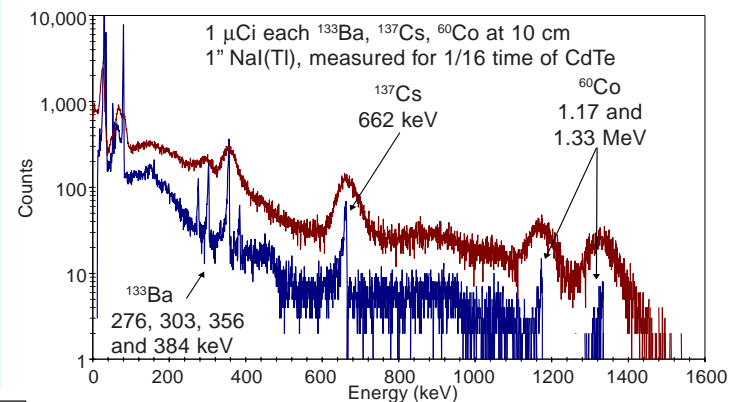

Figure 6. CdTe Stack and NaI(Tl) Comparison

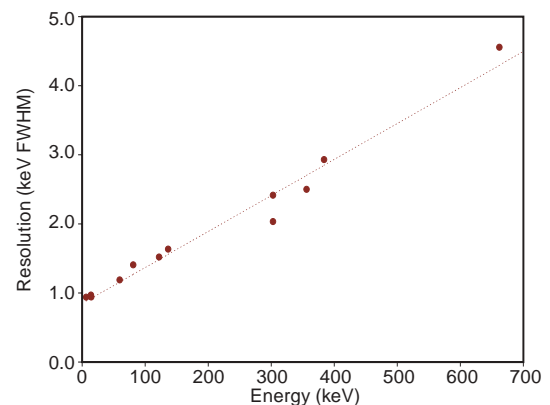

Figure 7. Energy Resolution

SPECIFICATIONS

MODEL XR-100T-CdTe-STACK X-RAY and GAMMA RAY DETECTOR

GENERAL

Detector Type:	CdTe-diode
Detector Area:	5 x 5 mm (25 mm ²)
Detector Thickness:	2.25 mm
Energy Resolution (typical):	1.5 keV FWHM @ 122 5 keV FWHM @ 662
Detector Window:	Be, 10 mil thick (250 µm)
Case Size:	3.75 x 1.75 x 1.13 in (9.5 x 4.4 x 2.9 cm)
Case Weight:	4.4 ounces (125 g)
Total Power:	Less than 1 Watt

INPUTS

Preamp Power:	± 8 Volts @ 25 mA
Detector Power:	+ 1400 Volts @ 1 µA
Cooler Power:	Current = 0.7 A maximum Voltage = 4.2 Volt maximum

OUTPUTS

1) Preamplifier	
Sensitivity:	0.14 mV/keV
Polarity:	Negative Signal Out (1 kΩ max. load)

2) Temperature Monitor

CONNECTIONS

Preamp Output:	BNC coaxial connector
Test Input:	BNC coaxial connector
Other connections:	6-Pin, LEMO connector with 5 ft cable

OPTIONS

- Other detector sizes (5 x 5 x 5 mm³) are available on special orders.
- Other Be window thicknesses are available.
- Components for vacuum applications.
- Collimator kit for high flux applications.
- See also XR-100T-CdTe X-Ray and Gamma Ray Detector specifications and XR-100CR specifications using Si-PIN for detection of low energy X-Rays with high resolution (186 eV FWHM @ 5.9 keV, ⁵⁵Fe).

6-PIN LEMO CONNECTOR ON THE XR-100T-CdTe

Pin 1:	+8 Volt temperature monitor power
Pin 2:	+ H.V. detector bias, + 1400 Volt max.
Pin 3:	-8 Volt preamp power
Pin 4:	+8 Volt preamp power
Pin 5:	Cooler power return
Pin 6:	Cooler power (0 to +4.2 Volt @ 0.7 A max.)
CASE:	Ground and shield

MODEL PX4 DIGITAL PULSE PROCESSOR and POWER SUPPLY

GAIN SETTINGS

Four programmable coarse gain settings are available: x10, x20, x50, x100. Fine gain is adjustable between 0.8 and 1.2.

PULSE SHAPE

Trapezoidal. A semi-gaussian amplifier with shaping time t has a peaking time of $2.2t$ and is comparable in performance with the trapezoidal shape of the same peaking time.

PEAKING and FLAT TOP TIMES

Twenty-four programmable peaking times between 0.8 and 102 msec. For each peak time, sixteen flat top durations are available, > 0.2 msec

RISE TIME DISCRIMINATOR (RTD)

The digital pulse processor can be programmed to select input pulses based on their rise time properties.

THROUGHPUT

The pulse processing electronics have a cycle time of 1 msec. With a peaking time of 0.8 msec, a 1MHz periodic signal can be acquired. Dead time is 1.25 x peaking time.

PILE-UP REJECT

Pulses separated by more than the fast channel resolving time, 600 nsec, and less than 1.25 x peaking time are rejected.

CHANNELS

Commandable to 256, 512, 1k, 2k, 4k, or 8k channels.

CONNECTIONS

Analog Input (BNC)

The analog input accepts pulses from the XR100 or any other detector with preamplifier reset or resistive feedback.

XR100 Power (6 pin LEMO)

Provides power to preamp and detector. Includes HV bias, thermoelectric cooler power, and preamp power.

Serial Interface (USB)

Standard USB interface to personal computer. Used for data acquisition and hardware control.

DAC Output (BNC)

This output is used in oscilloscope mode, to view the shaped pulse and other diagnostic signals. Range: 0 to 1 V.

Input Power

VDC (500 mA max) via power jack. It mates with a center positive 5.5 mm x 2.1 mm Power Plug.

Physical

Size: 6.5 x 5.5 x 1.5 inches (16.5 x 135 x 4.0 cm)
Weight: 1.6 lbs (750 g)

XR-100T-CdTe-STACK

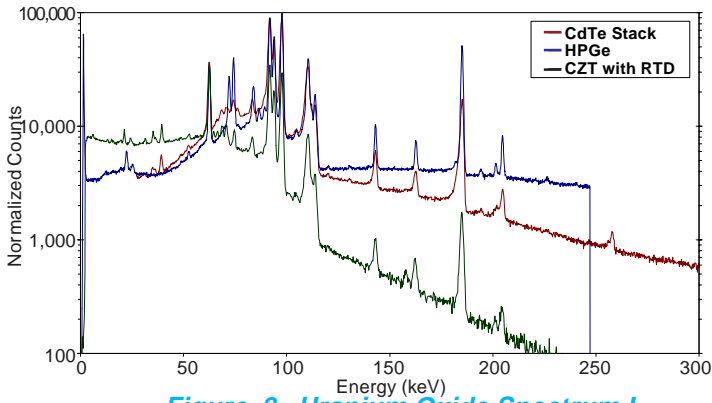

Figure 8. Uranium Oxide Spectrum I

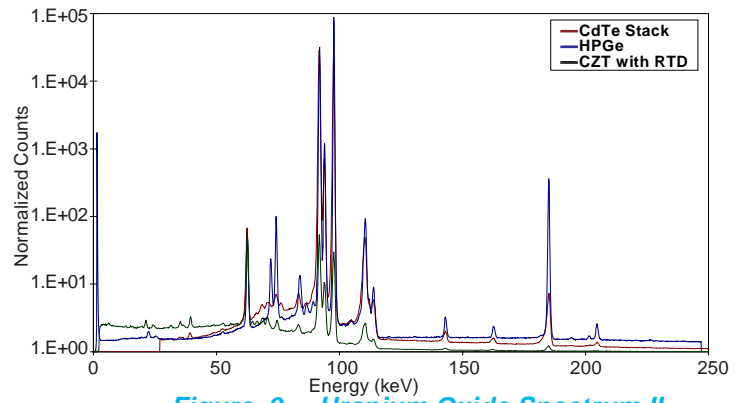

Figure 9. Uranium Oxide Spectrum II

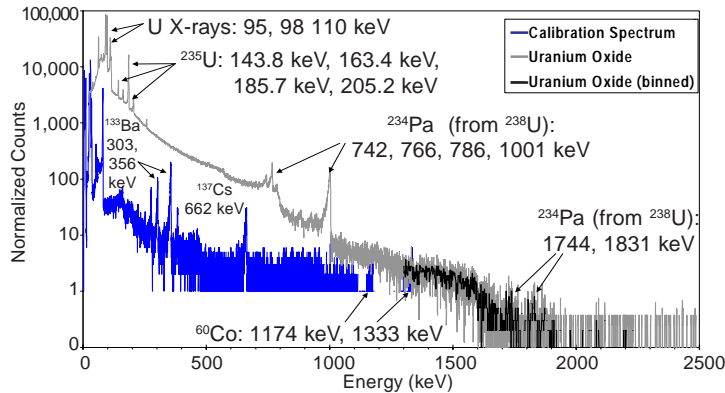

Figure 10. Uranium Oxide Spectrum III

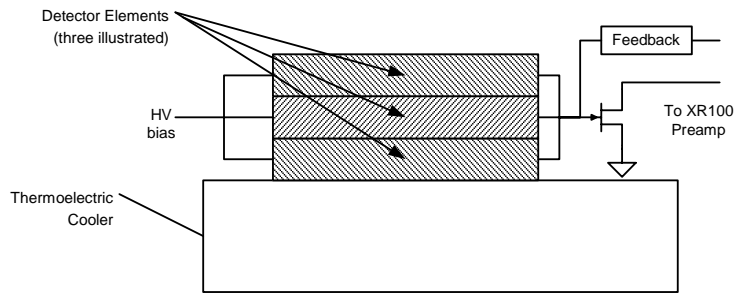

Figure 11. CdTe Stack Diagram

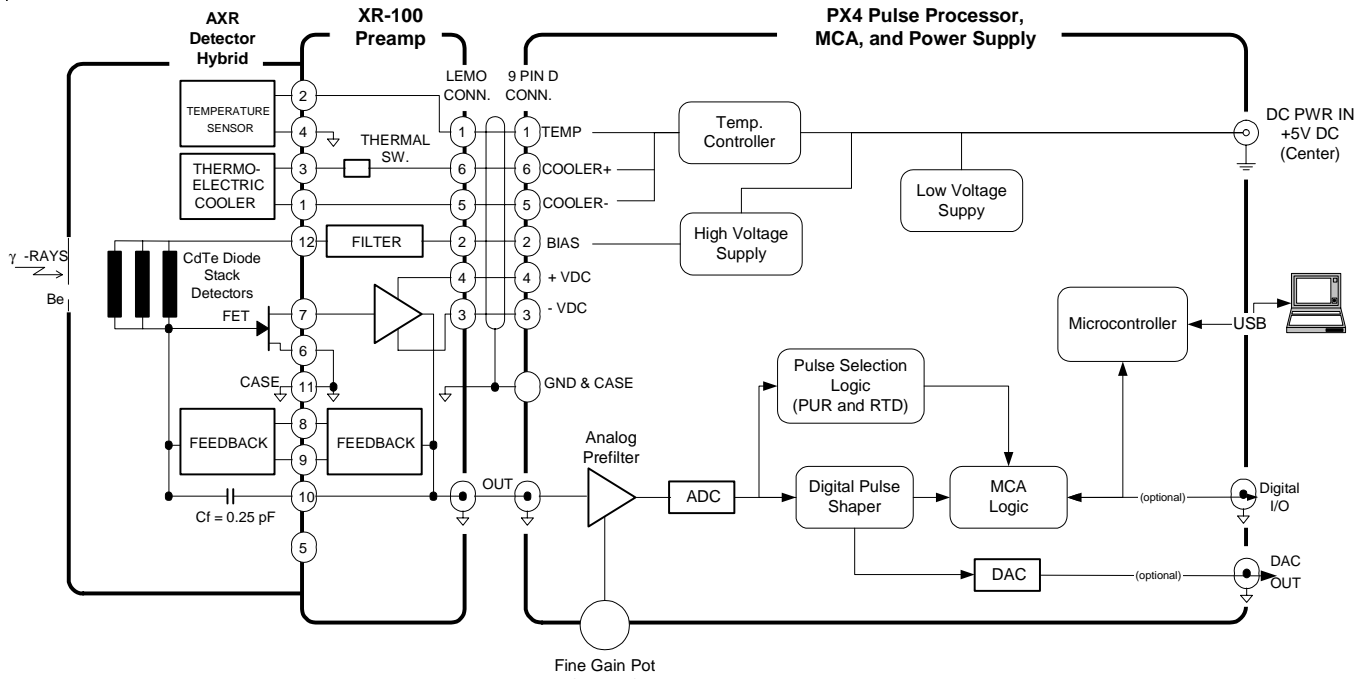

Figure 12. XR-100T-CdTe-Stack Connection Diagram

This diagram shows the internal connections between the AXRT-CdTe hybrid sensor and the electronics with the case, as well as the external connections to the PX4.

In Germany, Switzerland and Austria contact

AMPTEK INC.

6 De Angelo Drive
Bedford, MA 01730-2204 U.S.A.

Tel: +1 (781) 275-2242 Fax: +1 (781) 275-3470
email: sales@amptek.com www.amptek.com

FAST ComTec

FAST ComTec (www.fastcomtec.com)
Phone: +49-89-665180-50 FAX: +49-89-665180-40
e-mail: info@fastcomtec.com

